



CALL NO. 411

CONTRACT ID. 183235

OHIO COUNTY

FED/STATE PROJECT NUMBER 092GR18R028-CB06

DESCRIPTION VARIOUS ROUTES IN OHIO COUNTY

WORK TYPE ASPHALT SURFACE WITH BRIDGE

PRIMARY COMPLETION DATE 6/30/2019

LETTING DATE: October 26,2018

Sealed Bids will be received electronically through the Bid Express bidding service until 10:00 AM EASTERN DAYLIGHT TIME October 26,2018. Bids will be publicly announced at 10:00 AM EASTERN DAYLIGHT TIME.

NO PLANS ASSOCIATED WITH THIS PROJECT.

REQUIRED BID PROPOSAL GUARANTY: Not less than 5% of the total bid.

TABLE OF CONTENTS

PART I	SCOPE OF WORK
	<ul style="list-style-type: none">• PROJECT(S), COMPLETION DATE(S), & LIQUIDATED DAMAGES• CONTRACT NOTES• STATE CONTRACT NOTES• ASPHALT MIXTURE• DGA BASE• DGA BASE FOR SHOULDERS• INCIDENTAL SURFACING• FUEL AND ASPHALT PAY ADJUSTMENT• COMPACTION OPTION B• SPECIAL NOTE(S) APPLICABLE TO PROJECT• LIQUIDATED DAMAGES• WASTE AND BORROW SITES• BRIDGE DECK WATERPROOFING MEMBRANE & ASPH O'CONTRACTOR• SHOULDER PREPARATION• EDGE KEY (BY TON)• ASPHALT MILLING AND TEXTURING• TYPICAL SECTION DIMENSIONS• TRAFFIC CONTROL PLAN 2 LANE-CLOSED• DURABLE PAVEMENT EDGE DETAILS• BRIDGE RESTORATION & WATERPROOFING W/ CONCRETE OVERLAYS• TRAFFIC CONTROL PLAN• SKETCH MAP(S)• MATERIAL SUMMARY• SUMMARY SHEET(S)• TYPICAL SECTION(S)• BRIDGE DETAIL FOR PAVING PROJECT
PART II	SPECIFICATIONS AND STANDARD DRAWINGS
	<ul style="list-style-type: none">• SPECIFICATIONS REFERENCE• SUPPLEMENTAL SPECIFICATION• STANDARD DRAWINGS THAT APPLY
PART III	EMPLOYMENT, WAGE AND RECORD REQUIREMENTS
	<ul style="list-style-type: none">• LABOR AND WAGE REQUIREMENTS• EXECUTIVE BRANCH CODE OF ETHICS• KENTUCKY EQUAL EMPLOYMENT OPPORTUNITY ACT OF 1978 LOCALITY / STATE• PROJECT WAGE RATES / STATE
PART IV	INSURANCE
PART V	BID ITEMS

PART I
SCOPE OF WORK

ADMINISTRATIVE DISTRICT - 02

CONTRACT ID - 183235

092GR18R028-CB06

COUNTY - OHIO

PCN - 0209200852018

CB06 092 0085 007-012

KY 85 (KY 85) (MP 7.201) FROM KY 69 EXTENDING SOUTH TO US 62 (MP 11.292), A DISTANCE OF 04.09 MILES.ASPHALT RESURFACING

GEOGRAPHIC COORDINATES LATITUDE 37:23:06.70 LONGITUDE 86:59:12.63

PCN - 0209207622018

CB06 092 0762 000-003

KY 762 (KY 762) (MP 0.000) FROM KY 764 EXTENDING NORTH TO DAVIESS COUNTY LINE (MP 2.746), A DISTANCE OF 02.75 MILES.ASPHALT RESURFACING

GEOGRAPHIC COORDINATES LATITUDE 37:36:30.94 LONGITUDE 86:56:02.67

PCN - 0209212452018

CB06 092 1245 B00108N

KY 1245 (KY 1245) (MP 1.476) FROM 0.015 MILE NORTH OF KY 2719 EXTENING NORTH TO 0.061 MILE NORTH OF KY 2719 (MP 1.552), A DISTANCE OF 0.08 MILES.BRIDGE DECK OVERLAY

GEOGRAPHIC COORDINATES LATITUDE 37:19:54.20 LONGITUDE 86:57:47.69

COMPLETION DATE(S):

COMPLETED BY 06/30/2019

APPLIES TO ENTIRE CONTRACT

30 WORKING Days

APPLIES TO BRIDGE B00108N

CONTRACT NOTES

PROPOSAL ADDENDA

All addenda to this proposal must be applied when calculating bid and certified in the bid packet submitted to the Kentucky Department of Highways. Failure to use the correct and most recent addenda may result in the bid being rejected.

BID SUBMITTAL

Bidder must use the Department's electronic bidding software. The Bidder must download the bid file located on the Bid Express website (www.bidx.com) to prepare a bid packet for submission to the Department. The bidder must submit electronically using Bid Express.

JOINT VENTURE BIDDING

Joint venture bidding is permissible. All companies in the joint venture must be prequalified in one of the work types in the Qualifications for Bidders for the project. The bidders must get a vendor ID for the joint venture from the Division of Construction Procurement and register the joint venture as a bidder on the project. Also, the joint venture must obtain a digital ID from Bid Express to submit a bid. A joint bid bond of 5% may be submitted for both companies or each company may submit a separate bond of 5%.

UNDERGROUND FACILITY DAMAGE PROTECTION

The contractor shall make every effort to protect underground facilities from damage as prescribed in the Underground Facility Damage Protection Act of 1994, Kentucky Revised Statute KRS 367.4901 to 367.4917. It is the contractor's responsibility to determine and take steps necessary to be in compliance with federal and state damage prevention directives. When prescribed in said directives, the contractor shall submit Excavation Locate Requests to the Kentucky Contact Center (KY811) via web ticket entry. The submission of this request does not relieve the contractor from the responsibility of contacting non-member facility owners, whom shall be contacted through their individual Protection Notification Center. Non-compliance with these directives can result in the enforcement of penalties.

REGISTRATION WITH THE SECRETARY OF STATE BY A FOREIGN ENTITY

Pursuant to KRS 176.085(1)(b), an agency, department, office, or political subdivision of the Commonwealth of Kentucky shall not award a state contract to a person that is a foreign entity required by [KRS 14A.9-010](#) to obtain a certificate of authority to transact business in the Commonwealth ("certificate") from the Secretary of State under [KRS 14A.9-030](#) unless the person produces the certificate within fourteen (14) days of the bid or proposal opening. If the foreign entity is not required to obtain a certificate as provided in [KRS 14A.9-010](#), the foreign entity should identify the applicable exception. Foreign entity is defined within [KRS 14A.1-070](#).

For all foreign entities required to obtain a certificate of authority to transact business in the Commonwealth, if a copy of the certificate is not received by the contracting agency within the time frame identified above, the foreign entity's solicitation response shall be deemed non-responsive or the awarded contract shall be cancelled.

Businesses can register with the Secretary of State at <https://secure.kentucky.gov/sos/ftbr/welcome.aspx>.

SPECIAL NOTE FOR PROJECT QUESTIONS DURING ADVERTISEMENT

Questions about projects during the advertisement should be submitted in writing to the Division of Construction Procurement. This may be done by fax (502) 564-7299 or email to kytc.projectquestions@ky.gov. The Department will attempt to answer all submitted questions. The Department reserves the right not to answer if the question is not pertinent or does not aid in clarifying the project intent.

The deadline for posting answers will be 3:00 pm Eastern Daylight Time, the day preceding the Letting. Questions may be submitted until this deadline with the understanding that the later a question is submitted, the less likely an answer will be able to be provided.

The questions and answers will be posted for each Letting under the heading "Questions & Answers" on the Construction Procurement website (www.transportation.ky.gov/contract). The answers provided shall be considered part of this Special Note and, in case of a discrepancy, will govern over all other bidding documents.

HARDWOOD REMOVAL RESTRICTIONS

The US Department of Agriculture has imposed a quarantine in Kentucky and several surrounding states, to prevent the spread of an invasive insect, the emerald ash borer. Hardwood cut in conjunction with the project may not be removed from the state. Chipping or burning on site is the preferred method of disposal.

INSTRUCTIONS FOR EXCESS MATERIAL SITES AND BORROW SITES

Identification of excess material sites and borrow sites shall be the responsibility of the Contractor. The Contractor shall be responsible for compliance with all applicable state and federal laws and may wish to consult with the US Fish and Wildlife Service to seek protection under Section 10 of the Endangered Species Act for these activities.

ACCESS TO RECORDS

The contractor, as defined in KRS 45A.030 (9) agrees that the contracting agency, the Finance and Administration Cabinet, the Auditor of Public Accounts, and the Legislative Research Commission, or their duly authorized representatives, shall have access to any books, documents, papers, records, or other evidence, which are directly pertinent to this contract for the purpose of financial audit or program review. Records and other prequalification information confidentially

disclosed as part of the bid process shall not be deemed as directly pertinent to the contract and shall be exempt from disclosure as provided in KRS 61.878(1)(c). The contractor also recognizes that any books, documents, papers, records, or other evidence, received during a financial audit or program review shall be subject to the Kentucky Open Records Act, KRS 61.870 to 61.884.

In the event of a dispute between the contractor and the contracting agency, Attorney General, or the Auditor of Public Accounts over documents that are eligible for production and review, the Finance and Administration Cabinet shall review the dispute and issue a determination, in accordance with Secretary's Order 11-004.

April 30, 2018

SPECIAL NOTE FOR RECIPROCAL PREFERENCE

RECIPROCAL PREFERENCE TO BE GIVEN BY PUBLIC AGENCIES TO RESIDENT BIDDERS

By reference, KRS 45A.490 to 45A.494 are incorporated herein and in compliance regarding the bidders residency. Bidders who want to claim resident bidder status should complete the Affidavit for Claiming Resident Bidder Status along with their bid in the electronic bidding software. Submittal of the Affidavit should be done along the bid in Bid Express.

April 30, 2018

ASPHALT MIXTURE

Unless otherwise noted, the Department estimates the rate of application for all asphalt mixtures to be 110 lbs/sy per inch of depth.

DGA BASE

Unless otherwise noted, the Department estimates the rate of application for DGA Base to be 115 lbs/sy per inch of depth.

DGA BASE FOR SHOULDERS

Unless otherwise noted, the Department estimates the rate of application for DGA Base for Shoulders to be 115 lbs/sy per inch of depth. The Department will not measure necessary grading and/or shaping of existing shoulders prior to placing of DGA Base, but shall be incidental to the Contract unit price per ton for DGA Base.

Accept payment at the Contract unit price per ton as full compensation for all labor, materials, equipment, and incidentals for grading and/or shaping of existing shoulders and furnishing, placing, and compacting the DGA Base.

INCIDENTAL SURFACING

The Department has included in the quantities of asphalt mixtures established in the proposal estimated quantities required for resurfacing or surfacing mailbox turnouts, farm field entrances, residential and commercial entrances, curve widening, ramp gores and tapers, and road and street approaches, as applicable. Pave these areas to the limits as shown on Standard Drawing RPM-110-06 or as directed by the Engineer. In the event signal detectors are present in the intersecting streets or roads, pave the crossroads to the right of way limit or back of the signal detector, whichever is the farthest back of the mainline. Surface or resurface these areas as directed by the Engineer. The Department will not measure placing and compacting for separate payment but shall be incidental to the Contract unit price for the asphalt mixtures.

FUEL AND ASPHALT PAY ADJUSTMENT

The Department has included the Contract items Asphalt Adjustment and Fuel Adjustment for possible future payments at an established Contract unit price of \$1.00. The Department will calculate actual adjustment quantities after work is completed. If existing Contract amount is insufficient to pay all items on the contract with the adjustments, the Department will establish additional monies with a change order.

OPTION B

Be advised that the Department will control and accept compaction of asphalt mixtures furnished on this project under OPTION B in accordance with Sections 402 and 403.

SPECIAL NOTE FOR NON-TRACKING TACK COAT

1. DESCRIPTION AND USEAGE. This specification covers the requirements and practices for applying a non-tracking tack asphalt coating. Place this material on the existing pavement course, prior to placement of a new asphalt pavement layer. Use when expedited paving is necessary or when asphalt tracking would negatively impact the surrounding area. This material is not suitable for other uses. Ensure material can “break” within 15 minutes under conditions listed in 3.2.
2. MATERIALS, EQUIPMENT, AND PERSONNEL.

2.1 Non-Tracking Tack. Provide material conforming to Subsection 2.1.1.

2.1.1 Provide a tack conforming to the following material requirements:

Property	Specification	Test Procedure
Viscosity, SFS, 77 ° F	20 – 100	AASHTO T 72
Sieve, %	0.3 max.	AASHTO T 59
Asphalt Residue ¹ , %	50 min.	AASHTO T 59
Oil Distillate, %	1.0 max.	AASHTO T 59
Residue Penetration, 77 ° F	20 max.	AASHTO T 49
Original Dynamic Shear (G*/sin δ), 82 ° C	1.0 min.	AASHTO T 315
Softening Point, ° F	149 min.	AASHTO T 53
Solubility, %	97.5 min.	AASHTO T 44

¹ Bring sample to 212 °F over a 10-15 minute period. Maintain 212 °F for 15-20 minutes or until 30-40 mL of water has distilled. Continue distillation as specified in T59.

2.2. Equipment. Provide a distributor truck capable of heating, circulating, and spraying the tack between 170 °F and 180 °F. Do not exceed 180 °F. Circulate the material while heating. As required by the manufacturer, ensure the spray bar is equipped with #1 or #2 ¼” V-slot Etnyre nozzles. Other nozzles are not acceptable. Arrange the nozzles in the following patterns from left to right:

Nozzle number(s)	Activity	Orientation
1	On	Vertical
2	Off	-
3	On	Horizontal
4 & 5	Off	-
6	On	Horizontal
Continue 2 off and 1 on pattern through rest of spray bar system.		

Ensure the bar can be raised to between 14 and 18” from the roadway.

2.3 Personnel. Ensure the tack supplier has provided training to the contractor on the installation procedures for this product. Make a technical representative from the supplier available at the request of the Engineer.

3. CONSTRUCTION.

3.1 Surface Preparation. Prior to the application of the non-tracking tack, ensure the pavement surface is thoroughly dry and free from dust or any other debris that would inhibit adhesion. Clean the surface by scraping, sweeping, and the use of compressed air. Ensure this preparation process occurs shortly before application to prevent the return of debris pavement. If rain is expected within one hour after application, do not apply material. Apply material only when the surface is dry, and no precipitation is expected.

3.2 Non-tracking Tack Application. Ensure the roadway temperature is a minimum of 40 °F and rising during the application of the tack. This material is not suitable for use in colder temperatures. Prior to applying the tack, demonstrate competence in applying the tack according to this note to the satisfaction of the Engineer. Heat the tack in the distributor to between 170 – 180 °F. After initial heating to between 170 – 180 °F, the material may be sprayed between 165 °F and 180 °F. Do not apply outside this temperature range. Apply material at a rate of 0.50 pounds (0.06 gallons) per square yard. Ensure full coverage of the material on the pavement surface. Full coverage of this material is critical. If full coverage is not achieved, material application rate may be increased to ensure full coverage. Do not heat material more than twice in one day.

3.3 Non-tracking Tack Certification. Furnish the tacks certification to the Engineer stating the material conforms to all requirements herein prior to use.

3.4 Sampling and Testing. The Department will require a sample of non-tracking tack be taken from the distributor at a rate of one sample per 15,000 tons of mix. Take two 1 gallon samples of the heated material and forward the sample to the Division of Materials for testing within 7 days. Ensure the product temperature is between 170 and 180 °F at the time of sampling.

4. MEASUREMENT. The Department will measure the quantity of non-tracking tack in tons. The Department will not measure for payment any extra materials, labor, methods, equipment, or construction techniques used to satisfy the requirements of this note. The Department will not measure for payment any trial applications of non-tracking tack, the cleaning of the pavement surface, or furnishing and placing the adhesive. The Department will consider all such items incidental to the non-tracking tack.

5. PAYMENT. The Department will pay for the non-tracking tack at the Contract unit bid price and apply an adjustment for each manufacturer's lot of material based on the degree of compliance as defined in the following schedule. When a sample fails on two or more tests, the Department may add the deductions, but the total deduction will not exceed 100 percent.

Non-Tracking Tack Price Adjustment Schedule						
Test	Specification	100% Pay	90% Pay	80% Pay	50% Pay	0% Pay
Viscosity, SFS, 77 ° F	20 – 100	19 - 102	17 - 18	15 - 16	14	≤13
			103 - 105	106 - 107	108 - 109	≥ 110
Sieve, %	0.30 max.	≤ 0.40	0.41 - 0.50	0.51 - 0.60	0.61 - 0.70	≥ 0.71
Asphalt Residue, %	50 min.	≥49.0	48.5 – 48.9	48.0 – 48.4	47.5-47.9	≤ 47.4
Oil Distillate, %	1.0 max.	≤1.0	1.1-1.5	1.6 - 1.7	1.8-1.9	>2.0
Residue Penetration, 77 ° F	20 max.	≤ 21	22 - 23	24 - 25	26 - 27	≥ 28
Original Dynamic Shear (G*/sin δ), 82 ° C	1.0 min.	≥0.95	0.92 – 0.94	0.90 – 0.91	0.85 - 0.89	≤ 0.84
Softening Point, ° F	149 min.	≥145	142 - 144	140 - 141	138 - 139	≤ 137
Solubility, %	97.5 min.	≥ 97.0	96.8 – 96.9	96.6 – 96.7	96.4 – 96.5	≤ 96.3

<u>Code</u>	<u>Pay Item</u>	<u>Pay Unit</u>
24970EC	Asphalt Material for Tack Non-Tracking	Ton

April 30, 2018

SPECIAL NOTE FOR INSTALLING ARMORED EDGES FOR CONCRETE ON BRIDGES

- 1. DESCRIPTION.** Perform all work in accordance with the Kentucky Transportation Cabinet, Department of Highway's Standard Specifications for Road and Bridge Construction and applicable Supplemental Specifications, the Standard Drawings (Current Editions), this Note, and the attached detail drawings. Section references are to the Standard Specifications. This work consists of the following: (1) Furnish all labor, materials, tools, and equipment; (2) Remove existing concrete and expansion device(s) and/or bridge ends; (3) Install armored edges and new concrete as specified and in accordance with the attached detail drawings; (4) Install new joint seals (where required); (5) Maintain and control traffic; and (6) Any other work specified as part of this contract. See attached detailed drawings.
- 2. MATERIALS.**

 - A. Class "M" Concrete.** Use either "M1" or "M2". See Section 601.
 - B. Structural Steel.** Use new, commercial grade steel suitable for welding. The Engineer will base acceptance on visual inspection.
 - C. Stud Anchors.** The armored edge stud anchors are $\frac{3}{4}$ " embedded stud shear connectors conforming to ASTM A108, Grade 1015.
 - D. Steel Reinforcement.** Use Grade 60. See Section 602.
 - E. Epoxy Bond Coat.** See Section 511.
- 3. EQUIPMENT.**

 - A.** See Section 606.02.01
- 4. CONSTRUCTION.**

 - A. Remove Existing Materials.** Remove existing specified areas of concrete and armored edge as shown on the attached sketches. Remove debris as directed by the Engineer. Clean and leave all existing steel reinforcement encountered in place. Damaged steel reinforcement will be repaired/replaced as directed by the Engineer at no additional cost to the Department. Dispose of all removed material entirely away from the job site. This work is incidental to the contract unit price for "Armored Edge for Concrete".
 - B. Place New Concrete and Armored Edges.** After all specified existing materials have been removed; place new armored edges to match the grade of the proposed overlay or to match the original grade (See attached detail drawings). Place the new Class "M" concrete to the scarified grade and finish to receive the new overlay or place the new Class "M" concrete to the original grade and finish with broom strokes drawn transversely from curb to curb. All new structural steel shall be cleaned and painted in accordance with requirements of Section 607.03.23, except that surfaces to come in contact with concrete are not to be painted. Blast clean all areas of existing concrete and structural steel to come in contact with new concrete until free of all laitance and deleterious substances immediately prior to the placement of the Class "M" Concrete.

The surface areas of existing concrete to come in contact with the new Class "M" Concrete are to be coated with an epoxy bond coat immediately prior to placing new concrete in accordance with Section 511. The interfaces of the new and old concrete shall be as nearly vertical and horizontal as possible.

- C. Additional Steel Reinforcement.** Furnish for replacement, as directed by the Engineer, 400 linear feet of #4 steel reinforcing bars in 20' lengths. Place these bars in areas deemed by the Engineer to require additional reinforcement. Field cutting and bending is permitted. Do not place any additional steel reinforcement above the height of the top row of Nelson Studs on the armored edges. Ensure that all exposed steel reinforcement is tied in accordance with Section 602.03.04 prior to pouring the new Class "M" concrete. Deliver unused bars to the Local County Maintenance Barn. Payment will be made in accordance with Section 602.
 - D. Stage Construction.** Installation of concrete and armored edges in two (or more if specified) stages is necessary. Join the armored edges at or near the centerline of the roadway or lane line, field weld and grind smooth.
 - E. Damage to the Structure.** The Contractor shall bear all responsibility and expense for any and all damage to the structure during the repair work even to removal and replacement of a fall span, should the fallen span result from the Contractor's actions.
 - F. Shop Plans.** Shop plans will not be required. The Contractor is responsible for obtaining field measurements and supplying properly sized materials to complete the work.
- 5. MEASUREMENT.**
- A. Armored Edge for Concrete.** The Department will measure the quantity in linear feet from gutter line to gutter line along the centerline of the joint.
 - B. Steel Reinforcement.** See Section 602.
- 6. PAYMENT.**
- A. Armored Edge for Concrete (03294).** Payment at the contract unit price per linear foot shall be full compensation for furnishing and installing new armored edges at each end of bridge.
 - B. Steel Reinforcement (08150).** See Section 602.

SPECIAL NOTE FOR ELIMINATING TRANSVERSE JOINTS ON BRIDGES

1. **DESCRIPTION.** Perform all work in accordance with the Kentucky Transportation Cabinet, Department of Highway's Standard Specifications for Road and Bridge Construction and applicable Supplemental Specifications, the Standard Drawings (Current Editions), this Note, and the Attached Detailed Drawings. Section references are to the Standard Specifications. This work consists of the following: (1) Furnish all labor, materials, tools, and equipment; (2) Remove existing concrete and expansion device(s) (3) Place new concrete and steel reinforcement as specified (4) Maintain and control traffic; and (5) Any other work specified as part of this contract. See attached detailed drawings.

2. **MATERIALS.**
 - A. **Class "M" Concrete.** Use either "M1" or "M2". See Section 601.
 - B. **Steel Reinforcement.** Use Grade 60. See Section 602.
 - C. **Epoxy Bond Coat.** See Section 511.

3. **EQUIPMENT.**
 - A. **Hammer.** See Section 606.02.10 B.
 - B. **Sawing Equipment.** See Section 606.02.10 C.
 - C. **Hydraulic Impact Equipment.** See Section 606.02.10 D.

4. **CONSTRUCTION.**
 - A. **Remove Existing Materials.** Remove the existing transverse joints, joint filler, and specified areas of concrete as shown on the plans or as directed by the Engineer. Clean and leave all existing steel reinforcement encountered in place. Damaged steel reinforcement will be repaired/replaced as directed by the Engineer at no additional cost to the Department.
Dispose of all removed material entirely away from the job site. This work is incidental to the contract unit price for "Eliminate Transverse Joint".
 - B. **Additional Steel Reinforcement.** Furnish for this work steel reinforcing bars as shown on the plans. Splice these bars to the existing longitudinal reinforcement in the deck and curb/sidewalk in the areas of removed concrete to tie the slabs together as shown on the plans. Ensure that all exposed steel reinforcement is tied in accordance with Section 602.03.04 prior to pouring the new Class "M" concrete.
 - C. **Place New Concrete.** Blast-clean all areas of existing concrete and structural steel to come in contact with new concrete until free of all laitance and deleterious substances immediately prior to the placement of the Class "M" Concrete. The surface areas of existing concrete to come in contact with the new Class "M" Concrete are to be coated with an epoxy bond coat immediately prior to placing new concrete in accordance with Section 511. The interfaces of the new and old concrete shall be as nearly vertical and horizontal as possible. Place new Class "M" Concrete to the specified grade and finish to receive the new overlay or as shown on the plans. On the sidewalk and curb, place the new concrete to original grade and finish to match the existing curb/sidewalk. Repair all pavement striping that is disturbed.

- D. Stage Construction.** Installation of concrete in two (or more if specified) stages is necessary.
- E. Residual Lead.** Residual lead paint may still be on bridge. The Contractor is advised to take all necessary protective measures including worker safety and environmental regulations when performing surface preparation. The Department will not consider any claims based on residual lead paint.
- F. Verifying Field Conditions.** The Contractor shall field verify all dimensions before ordering any material. New material that is unsuitable due to variation in existing structure shall be replaced at the Contractors expense.
- G. Damage to the Structure.** The Contractor shall bear all responsibility and expense for any and all damage to the structure during the repair work even to removal and replacement of a fall span, should the fallen span result from the Contractor's actions.

5. MEASUREMENT.

- A. Eliminate Transverse Joint.** The Department will measure the quantity in linear feet from plinth to plinth perpendicular to the centerline of the bridge.
- B. Steel Reinforcement.** See Section 602.

6. PAYMENT.

- A. Eliminate Transverse Joint (03300).** Payment at the contract unit price per linear foot is full compensation for furnishing equipment, labor, tools and materials needed to complete removal and disposal of the specified existing materials, cleaning and straightening of existing steel reinforcement, furnishing and installing the concrete, repairing traffic striping and all incidental items necessary to complete the work within the specified pay limits as specified by this note and as shown on the attached detail drawings.
- B. Steel Reinforcement (08150).** See Section 602.

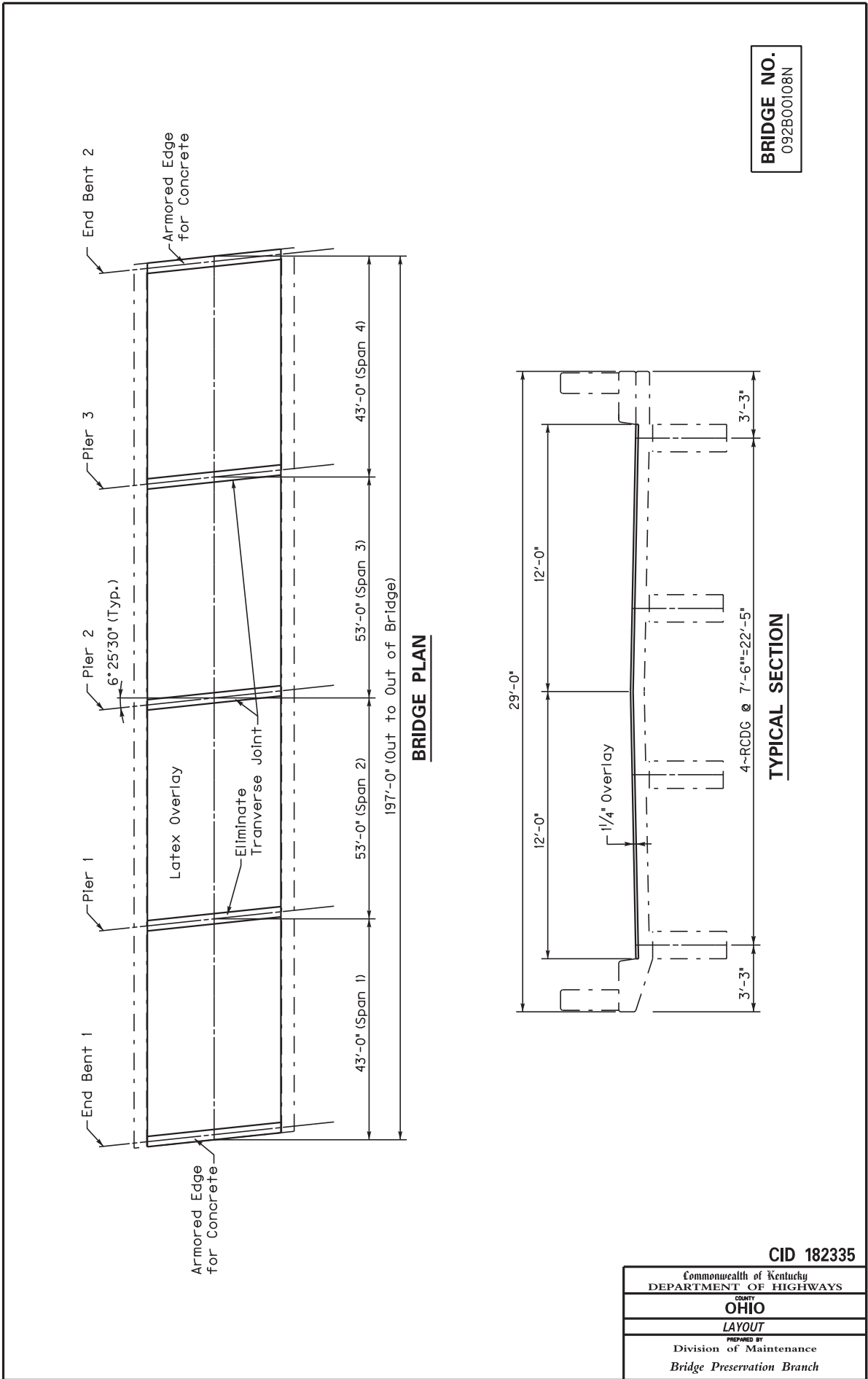

BRIDGE NO.
092B00108N

BRIDGE PLAN

TYPICAL SECTION

CID 182335

Commonwealth of Kentucky DEPARTMENT OF HIGHWAYS
COUNTY OHIO
LAYOUT
PREPARED BY Division of Maintenance Bridge Preservation Branch

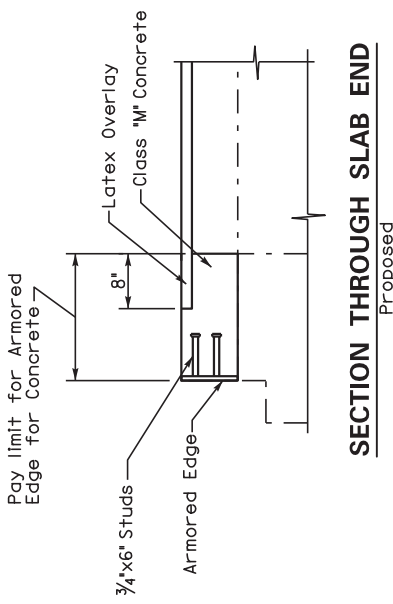

SECTION THROUGH SLAB END
Proposed

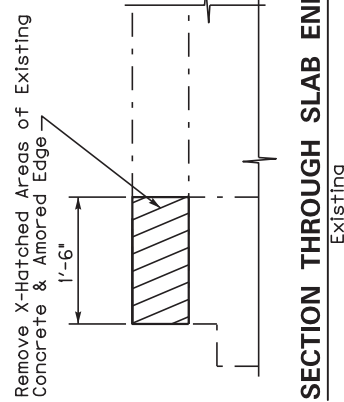

SECTION THROUGH SLAB END
Existing

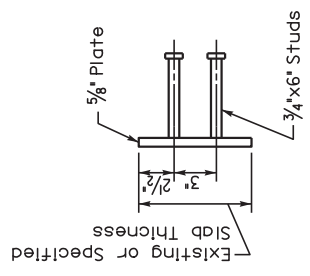

SECTION A-A

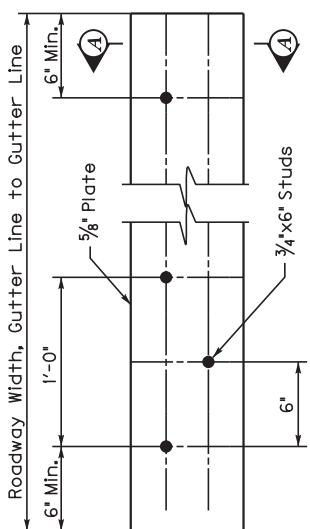

ARMORED EDGE

BRIDGE NO.
092B00108N

NOTE: SPECIAL NOTE FOR INSTALLING ARMORED EDGES FOR CONCRETE ON BRIDGES

CID 182335

Commonwealth of Kentucky DEPARTMENT OF HIGHWAYS
COUNTY OHIO
ARMORED EDGE FOR CONCRETE
PREPARED BY Division of Maintenance Bridge Preservation Branch

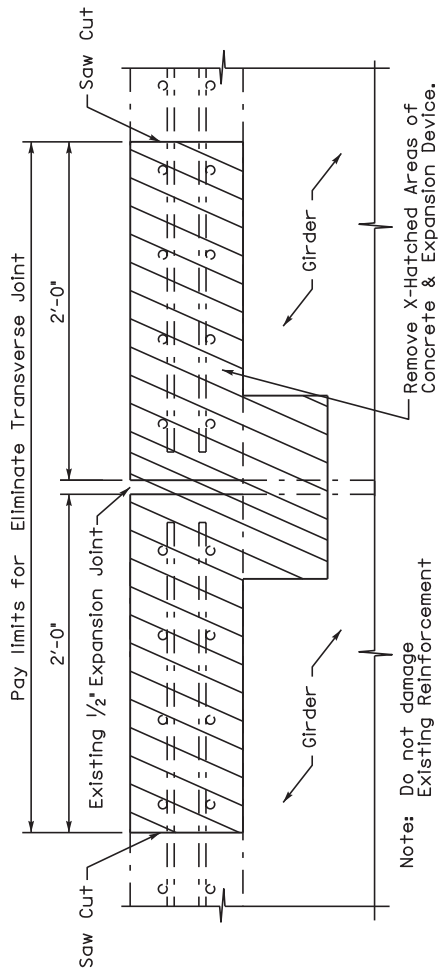

SECTION THROUGH JOINT
(Existing)

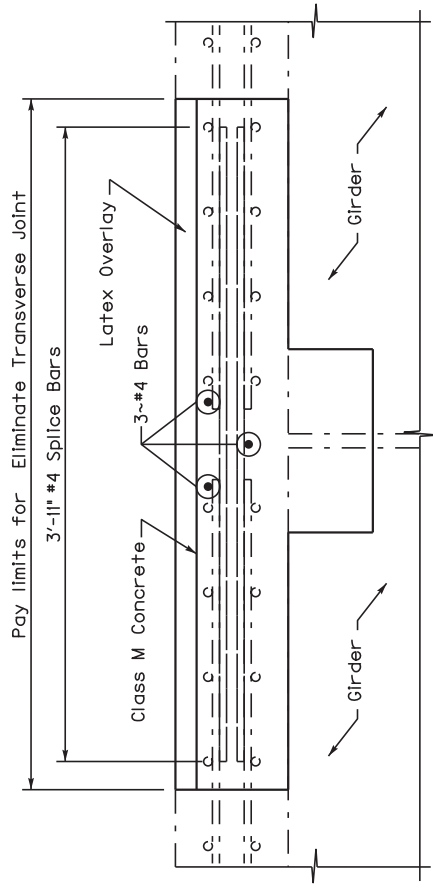

SECTION THROUGH JOINT
(Proposed)

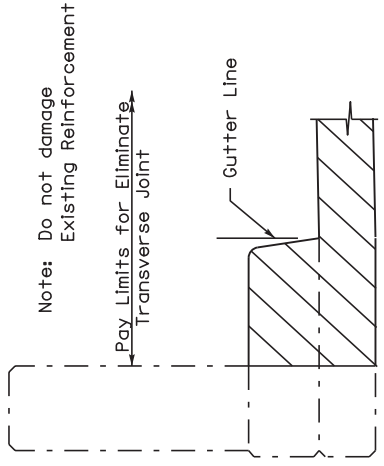

SECTION THROUGH PAPAPET
(Existing)

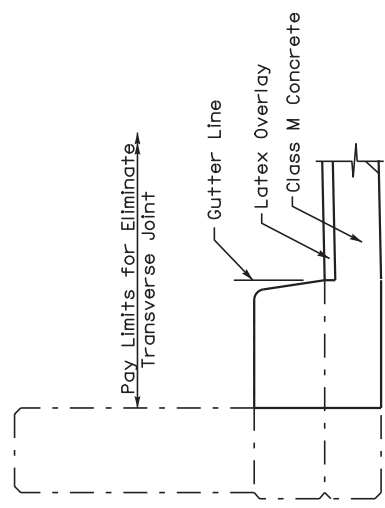

SECTION THROUGH PAPAPET
(Proposed)

BRIDGE NO.
092B00108N

Note: See Special Note for Eliminating Transverse Joints on Bridges

CID 182335

Commonwealth of Kentucky DEPARTMENT OF HIGHWAYS
OHIO
ELIMINATE TRANSVERSE JOINT
PREPARED BY Division of Maintenance Bridge Preservation Branch

SPECIAL NOTE FOR CONTRACT COMPLETION DATE AND LIQUIDATED DAMAGES ON BRIDGE REPAIR
CONTRACTS – KY 1245

- I. **COMPLETION DATE.** The contractor has the option of selection the starting date for this Contract. Once selected, notify the Department in writing of the date selected at least two weeks prior to the beginning work. An allotted number of calendar days are assigned to each structure in the contract as shown below.

<u>STRUCTURE</u>	<u>NUMBER OF DAYS</u>
<u>092B00108N</u>	<u>30</u>

Contrary to Section 108.07.02, the Engineer will begin charging Working days for a structure on the day the Contractor starts work or sets up traffic control on that particular structure.

- II. **LIQUIDATED DAMAGES.** Liquidated damages will be assessed the Contractor in accordance with the Transportation Cabinet, Dept. of Highway's 2012 Standard Specifications for Road and Bridge Construction, Section 108.09, when either the allotted number of days or the **June 30, 2019** date is exceeded.

Contrary to the Standard Specifications, liquidated damages will be assessed the Contractor during the months of September, October, November, December, January, February, and March when the contract time has expired on any individual bridge or bridges. Contract time will be charged during these months.

All construction must be completed in accordance with the weather limitations specified in Section 606 and/or Section 601 as applicable. No extension on Contract time will be granted due to inclement weather or temperature limitation that occur due to starting work on the Contract or a structure late in the construction season.

SPECIAL PROVISION FOR WASTE AND BORROW SITES

Obtain U.S. Army Corps of Engineer's approval before utilizing a waste or borrow site that involves "Waters of the United States". The Corps of Engineers defines "Waters of the United States" as perennial or intermittent streams, ponds or wetlands. The Corps of Engineers also considers ephemeral streams, typically dry except during rainfall but having a defined drainage channel, to be jurisdictional waters. Direct questions concerning any potential impacts to "Waters of the United States" to the attention of the appropriate District Office for the Corps of Engineers for a determination prior to disturbance. Be responsible for any fees associated with obtaining approval for waste and borrow sites from the U.S. Army Corps of Engineer or other appropriate regulatory agencies.

1-296 Waste & Borrow Sites
01/02/2012

SPECIAL NOTE FOR BRIDGE DECK WATERPROOFING MEMBRANE AND ASPHALT OVERLAY ON BRIDGES

I. DESCRIPTION

Except as specified herein, perform all work in accordance with the Department's Standard and Supplemental Specifications and Standard and Sepia Drawings, current editions. Article references are to the Standard Specifications. Furnish all materials, labor, equipment, and incidentals necessary to complete the One Step Bridge Deck Waterproofing Membrane.

II. MATERIALS

A. Maintain and Control Traffic. See Traffic Control Plan

B. One Step Membrane. See Section 808.

C. Asphalt Overlay. Use the same class and type of asphalt surface mixture that is being placed on the adjacent roadway.

III. CONSTRUCTION METHODS

A. Maintain and Control Traffic. See Traffic Control Plan

B. Remove Asphalt Overlay. When the bridge deck has an existing asphalt overlay, totally remove the overlay by milling and texturing, scarification, or other approved methods. Dispose of material off the right of way at sites obtained by the Contractor at no additional cost to the Department (See Special Note for Waste and Borrow).

C. Surface Preparation. After removal of the asphalt overlay, thoroughly clean the entire surface area of the bridge deck prior to paving by either air blasting or water blasting. If water blasting is used, thoroughly dry the area prior to placing the primer and membrane. Do not allow traffic on the cleaned bridge deck prior to applying the primer.

One Step Membrane
Page 2 of 3

D. Prime Coating. Apply primer material to the bridge deck according to the Manufacturer's recommendations. Do not allow traffic on the primed bridge deck prior to placing the membrane.

E. One Step Membrane. Apply the membrane to the entire surface of the bridge deck. Overlap the membrane a minimum of 1 foot onto the adjacent roadway approaches. Extend the membrane up the face of the curbs a minimum of 1½ inches or the thickness of the asphalt overlay, whichever is greater. Overlap membrane as necessary to achieve 100% coverage of the bridge deck. Install as recommended by the manufacturer, straight and wrinkle free, with no curled or uplifted edges. Do not allow traffic on the membrane prior to placing the asphalt surface.

F. Asphalt Surface. Place the asphalt surface immediately after the membrane is in place. For crowned bridge decks, place the asphalt overlay so that it is 1" thicker than the nominal thickness specified in the Contract at the bridge centerline and taper to the specified nominal thickness at the gutter line. The intent is to increase the crown to accelerate water runoff from the bridge deck. For superelevated bridge decks, place the asphalt overlay at the nominal thickness specified in the Contract.

IV. METHOD OF MEASUREMENT

A. Maintain and Control Traffic. See Traffic Control Plan

B. Remove Asphalt Overlay. Regardless of the method of removal, the Department will measure removal of the existing asphalt overlay according to Section 408.04.01. If the Contract or the Engineer requires removal to be accomplished by milling and texturing, the Department will measure Mobilization for Asphalt Milling and Texturing according to Section 408.04.02.

C. One Step Membrane. The Department will measure the One Step Membrane in square yards. The Engineer will calculate the area of one step membrane (A) from the length of the bridge (L) plus 1 foot on each approach multiplied by the curb to curb width of the bridge (W):

$$A = \frac{(L+2) \times W}{9}$$

The Engineer will not measure surface preparation, primer, laps, cutoffs and waste for payment.

One Step Membrane
Page 3 of 3

V. METHOD OF PAYMENT

A. Maintain and Control Traffic. See Traffic Control Plan

B. Remove Asphalt Overlay. Regardless of the method of removal, the Department will pay for removal of the existing asphalt overlay according to Section 408.05.01.

C. One Step Membrane. Payment at the contract unit price per square yard shall be full compensation for all labor, equipment, materials and incidentals for surface preparation and furnishing and placing the surface primer and the one step membrane according to the Manufacturer's recommendations and these notes.

1-3108 Waterproof Membrane by Contractor
01/02/2012

SPECIAL NOTE FOR SHOULDER PREPARATION

Grade, shape, and compact shoulder as shown on the typical section and as directed by the Engineer to provide proper template and foundation for the shoulder resurfacing. The Department will not measure grading, shaping, and compacting shoulders for separate payment, but shall be incidental to the asphalt base and/or surface placed on the shoulder.

1-3245 Shoulder Preparation Contractor
01/02/2012

SPECIAL NOTE FOR EDGE KEY

Construct Edge Keys at the beginning of project, end of project, at railroad crossings, and at ramps, as applicable. Unless specified in the Contract or directed by the Engineer, do not construct edge keys at intersecting streets, roads, alleys, or entrances. Cut out the existing asphalt surface to the required depth and width shown on the drawing and heel the new surface into the existing surface. The Department will make payment for this work at the Contract unit price per ton for Asphalt Pavement Milling and Texturing, which shall be full compensation for all labor, materials, equipment, and incidentals for removal and disposal of the existing asphalt surface required to construct the edge key.

EDGE KEY

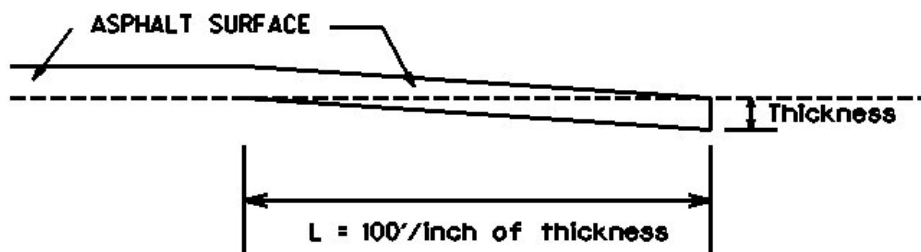

Thickness = 1 Inch

L = 100 LF

L= Length of Edge Key

1-3309 Edge key by Ton
01/02//2012

**SPECIAL NOTE FOR
ASPHALT MILLING AND TEXTURING**

Begin paving operations within **48 hours** of commencement of the milling operation. Continue paving operations continuously until completed. If paving operations are not begun within this time period, the Department will assess liquidated damages at the rate prescribed by Section 108.09 until such time as paving operations are begun.

Take possession of the millings and recycle the millings or dispose of the millings off the Right-of-Way at sites obtained by the Contractor at no additional cost to the Department.

1-3520 48 hours Contractor keeps millings
01/2/2012

SPECIAL NOTE FOR TYPICAL SECTION DIMENSIONS

Consider the dimensions shown on the typical sections for pavement and shoulder widths and thickness' to be nominal or typical dimensions. The Engineer may direct or approve varying the actual dimensions to be constructed to fit existing conditions. Do not widen existing pavement or shoulders unless specified elsewhere in this proposal or directed by the engineer.

1-3725 Typical Section Dimensions
01/02/2012

TRAFFIC CONTROL PLAN – KY 1245

TRAFFIC CONTROL GENERAL

Except as provided herein, maintain and control traffic in accordance with the Standard and Supplemental Specifications and the Standard and Sepia Drawings, current editions. Except for the roadway and traffic control bid items listed, all items of work necessary to maintain and control traffic will be paid at the lump sum bid price to "Maintain and Control Traffic".

Contrary to Section 106.01, furnish new, or used in like new condition, traffic control devices at the beginning of the work and maintain in like new condition until completion of the work.

PROJECT PHASING & CONSTRUCTION PROCEDURES

The Engineer may specify days and hours when lane and/or road closures will not be allowed.

The Contractor may close road to through traffic during construction. When road is closed to through traffic, maintain alternating one way local traffic during construction (see Standard Drawing TTC-105-02). Provide a minimum clear lane width of 10 feet. If traffic should be stopped due to construction operations, and a school bus on an official run arrives on the scene, make provisions for the passage of the bus as quickly as possible.

LANE CLOSURES

Do not leave lane closures in place during non-working hours.

SIGNS

Contrary to section 112.04.02, only long term signs (signs intended to be continuously in place for more than 3 days) will be measured for payment; short term signs (signs intended to be left in place for 3 days or less) will not be measured for payment but will be incidental to Maintain and Control Traffic.

CHANGEABLE MESSAGE SIGNS

If deemed necessary by the Engineer, the Department will furnish, operate, and maintain Changeable Message Signs.

Traffic Control Plan
Page 2 of 3

BARRICADES

The Department will not measure barricades used in lieu of barrels and cones for channelization or delineation, but shall be incidental to Maintain and Control Traffic according to Section 112.04.01.

The Department will measure barricades used for road closures and to protect pavement removal areas in individual units Each. The Department will measure for payment the maximum number of barricades in concurrent use at the same time on a single day on all sections of the contract. The Department will measure individual barricades only once for payment, regardless of how many times they are set, reset, removed, and relocated during the duration of the project. The Department will not measure replacements for damaged barricades the Engineer directs to be replaced due to poor condition or reflectivity. Retain possession of the Barricades upon completion of construction.

PAVEMENT MARKINGS

If there is to be a deviation from the existing striping plan, the Engineer will furnish the Contractor a striping plan prior to placement of the final surface course.

Install Temporary Striping according to Section 112 with the following exception:

If the Contractor's operations or phasing requires temporary markings that must subsequently be removed from the final surface course, use an approved removable lane tape; however, the Department will not measure removable lane tape for separate payment, but will measure and pay for removable lane tape as temporary striping.

PAVEMENT EDGE DROP-OFFS

Do not allow a pavement edge between opposing directions of traffic or lanes that traffic is expected to cross in a lane change situation with an elevation difference greater than 1½". Place Warning signs (MUTCD W8-11 or W8-9A) in advance of and at 1500' intervals throughout the drop-off area. Dual post the signs on both sides of the traveled way. Wedge all transverse transitions between resurfaced and unresurfaced areas which traffic may cross with asphalt mixture for leveling and wedging. Remove the wedges prior to placement of the final surface course.

Protect pavement edges that traffic is not expected to cross, except accidentally, as follows:

Less than 2" - No protection required.

Traffic Control Plan
Page 3 of 3

2" to 4" - Place plastic drums, vertical panels, or barricades every 50 feet. During daylight working hours only, the Engineer will allow the Contractor to use cones in lieu of plastic drums, panels, and barricades. Wedge the drop-off with DGA or asphalt mixture for leveling and wedging with a 1:1 or flatter slope in daylight hours, or 3:1 or flatter slope during nighttime hours, when work is not active in the drop-off area.

Greater than 4' - Protect drop-offs greater than 4 inches within 10 feet of traffic by placing drums, vertical panels, or barricades every 25 feet. The Engineer will not allow the use of cones in lieu of drums, vertical panels, or barricades for drop-offs greater than 4". Place Type III Barricades directly in front of the drop-off facing on coming traffic in both directions of travel. Provide warning signs as shown on the Standard Drawings or as directed by the Engineer

Pedestrians & Bicycles - Protect pedestrian and bicycle traffic as directed by the engineer.

DURABLE PAVEMENT EDGE DETAIL

(Resurfacing adjacent to fill slope or ditch foreslope that is 3:1 or less)

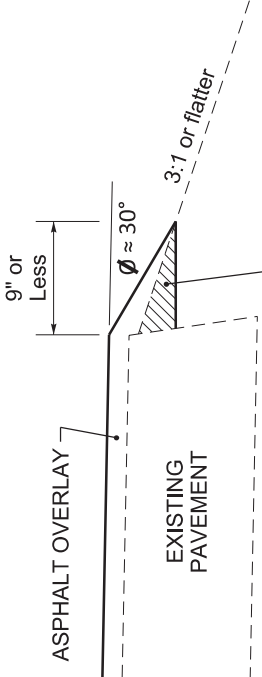

PREPARE SHOULDER ACCORDING TO STANDARD SPECIFICATIONS

DURABLE PAVEMENT EDGE DETAIL

(Resurfacing adjacent to fill slope or ditch foreslope that is steeper than 3:1)

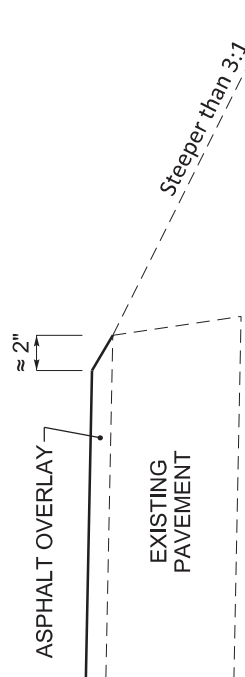

DURABLE PAVEMENT EDGE DETAIL

(Resurfacing adjacent to low shoulder with dropoff of 5 inches or less)

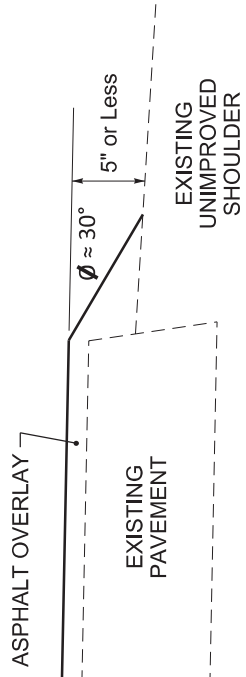

DURABLE PAVEMENT EDGE DETAIL

(Resurfacing adjacent to low shoulder with dropoff of more than 5 inches)

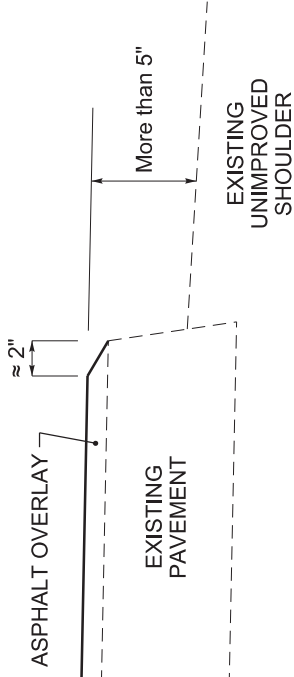

DURABLE PAVEMENT EDGE DETAIL

(Resurfacing adjacent to an obstruction, such as an existing headwall)

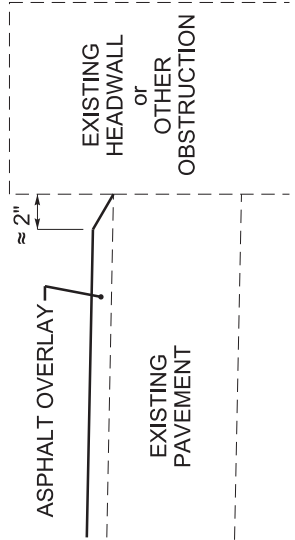

NOTES

1. DETAILS DO NOT APPLY TO OVERLAYS LESS THAN 1 INCH THICK.
2. THE DURABLE PAVEMENT EDGE DEVICE MAY BE DISENGAGED AT DRIVEWAYS, SIDE STREETS, HIGH SHOULDERS, AND OTHER LOCATIONS NOT FEASIBLE TO CONSTRUCT, AS APPROVED BY THE ENGINEER.

DRAWING NOT TO SCALE

DURABLE PAVEMENT EDGE DETAILS

SPECIAL NOTE FOR BRIDGE RESTORATION AND WATERPROOFING WITH CONCRETE OVERLAYS

- I. DESCRIPTION.** Perform all work in accordance with the Kentucky Transportation Cabinet, Department of Highway's 2012 Standard Specifications for Road and Bridge Construction and applicable Supplemental Specifications, the Standard Drawings, this Note, and the attached detail drawings. Section references are to the Standard Specifications.

This work consists of the following: (1) Furnish all labor, materials, tools, and equipment; (2) Machine prep the existing slab; (3) Complete full-depth and partial depth repairs as directed by the Engineer; (4) Repair/replace damaged and corroded reinforcing bars; (5) Place new concrete overlay and epoxy-sand slurry in accordance with Section 606; (6) Complete asphalt approach pavement; (7) Maintain and control traffic; and (8) Any other work specified as part of this contract.

All construction will be in accordance with Section 606 unless otherwise specified.

II. MATERIALS.

- A. Latex Concrete.** See Section 606.03.17.
- B. Class "M" Concrete.** Use either "M1" or "M2". See Section 601.
- C. Bituminous Asphalt.** Use **CL2 ASPH SURF 0.38D PG64-22**.
- D. Epoxy-Sand Slurry.** See Section 606.03.10.

III. CONSTRUCTION.

- A. Machine prep of existing slab.** Remove concrete from existing slab to a depth of at least ¼" below the existing surface, and remove all patches completely, in accordance with the requirements of Section 606.03.03.
- B. Partial Depth Slab Repair and Latex Overlay.** Remove areas determined to be unsound by the Engineer via hydrodemolition or via hand held jackhammers weighing less than 45lbs in accordance with Section 606.02.10 D. Repair/Replace all damaged or severely corroded reinforcing bars prior to partial depth repair operation. The Department will not measure material removal and will consider this work incidental to the bid item "PARTIAL DEPTH PATCHING". Mix and place Latex Modified Concrete Overlay in accordance with Sections 606.03.08 and 606.03.17.
- C. Asphalt Approach Pavement.** Mill each existing asphalt approach for a distance of 100' from the bridge end. Remove the bituminous material uniformly by making an edge key, so as to provide a smooth transition to the finished bridge when a new bituminous overlay of compacted depth of approximately 1½" is added to the approaches. The grinding depth may vary depending of the condition of the existing approach and final elevation of bridge end. Dispose of all removed material away from the site.
- D. Surface Texturing.** Texture the concrete surface of the overlay in accordance with Section 609.03.10.

IV. MEASUREMENT. See Section 606 and the following:

A. Latex Modified Concrete for Overlay. The Department will measure the quantity in cubic yards using the theoretical volume as follows for each bridge:

$$092B00108N \quad (197' \times 24' \times 1.25") = 19 \text{ cuyd}$$

B. Latex Modified Concrete for Partial Depth Patching and variable thickness of Overlay. The Department will measure the quantity in cubic yards by deducting the theoretical volume of bridge deck overlay (LMC) from the total volume (as indicated by the batch quantity tickets) of Concrete required to obtain the finished grade shown on the Plans or established by the Engineer.

C. Machine Prep of Slab. The Department will measure the machine preparation of the existing bridge deck in square yards, which shall include all labor, equipment, and material needed to complete this work.

D. Steel Reinforcement. The Department will measure any reinforcing steel necessary for the partial or full depth patch in pounds, which shall include all labor, equipment, and material needed to complete this work.

E. Asphalt Approach Pavement. The Department will measure the quantity in square yards, which shall include all labor, equipment, and material needed to complete this work.

V. PAYMENT. See Section 606 and the following:

A. Latex Modified Concrete for Overlay. The Department will make payment for the Latex Modified Concrete under bid item #08534 "CONCRETE OVERLAY – LATEX" for the quantity in cubic yards complete in place.

B. Latex Modified Concrete for Partial Depth Patching and variable thickness of Overlay. The Department will make payment for the Partial Depth Patching under bid item #24094EC "PARTIAL DEPTH PATCHING". Payment will be for the quantity per cubic yard complete in place.

C. Machine Prep of Slab. The Department will make payment for the removal of the existing overlay under bid item #08551 "MACHINE PREP OF SLAB". Payment will be for the square yard complete.

D. Steel Reinforcement. The Department will make payment for steel reinforcement, if necessary, under bid item #08150 "STEEL REINFORCEMENT". Payment will be at the unit price per pound.

E. Asphalt Approach Pavement. The Department will make payment for the completed and accepted quantity of this work under the bid item #03304 "BRIDGE OVERLAY APPROACH PAVEMENT".

TRAFFIC CONTROL PLAN

TRAFFIC CONTROL GENERAL

Except as provided herein, traffic shall be maintained in accordance with the current editions of the Standard Specifications and Standard Drawings. Except for the roadway and traffic control bid items listed, all items of work necessary to maintain and control traffic will be paid at the lump sum bid price to "Maintain and Control Traffic".

Contrary to Section 106.01, traffic control devices used on this project may be new, or used in like new condition, at the beginning of the work and maintained in like new condition until completion of the work.

PROJECT PHASING & CONSTRUCTION PROCEDURES

At the discretion of the Engineer, days and hours may be specified when lane closures will not be allowed.

The Contractor may maintain alternating one way traffic during construction if the surface width is 16 feet or greater. The clear lane width shall be a minimum of 8 feet. If traffic should be stopped due to construction operations, and a school bus on an official run arrives on the scene, the Contractor shall make provisions for the passage of the bus as quickly as possible.

LANE CLOSURES

Lane closures shall not be left in place during non-working hours.

PAVEMENT EDGE DROP-OFFS

A pavement edge between opposing directions of traffic or lanes that traffic is expected to cross in a lane change situation shall not have an elevation difference greater than 1½". Warning signs (MUTCD W8-11 or W8-9A) shall be placed in advance of and at 1500 foot intervals throughout the drop-off area. Dual posting on both sides of the traveled way shall be required. All transverse transitions between resurfaced and unresurfaced areas which traffic may cross shall be wedged with asphalt mixture for leveling and wedging. The wedges shall be removed prior to placement of the final surface course.

Pavement edges that traffic is not expected to cross, except accidentally, shall be treated as follows:

- Less than 2" - No protection required.
- 2" to 4" - Place plastic drums, vertical panels, or barricades every 50 feet. Cones may be used in place of plastic drums, panels, and barricades during daylight working hours. Wedge with asphalt mixture for leveling and wedging with a 1:1 or flatter slope in daylight hours, or 3:1 or flatter slope during nighttime hours, when work is not active in the drop-off area.

OHIO

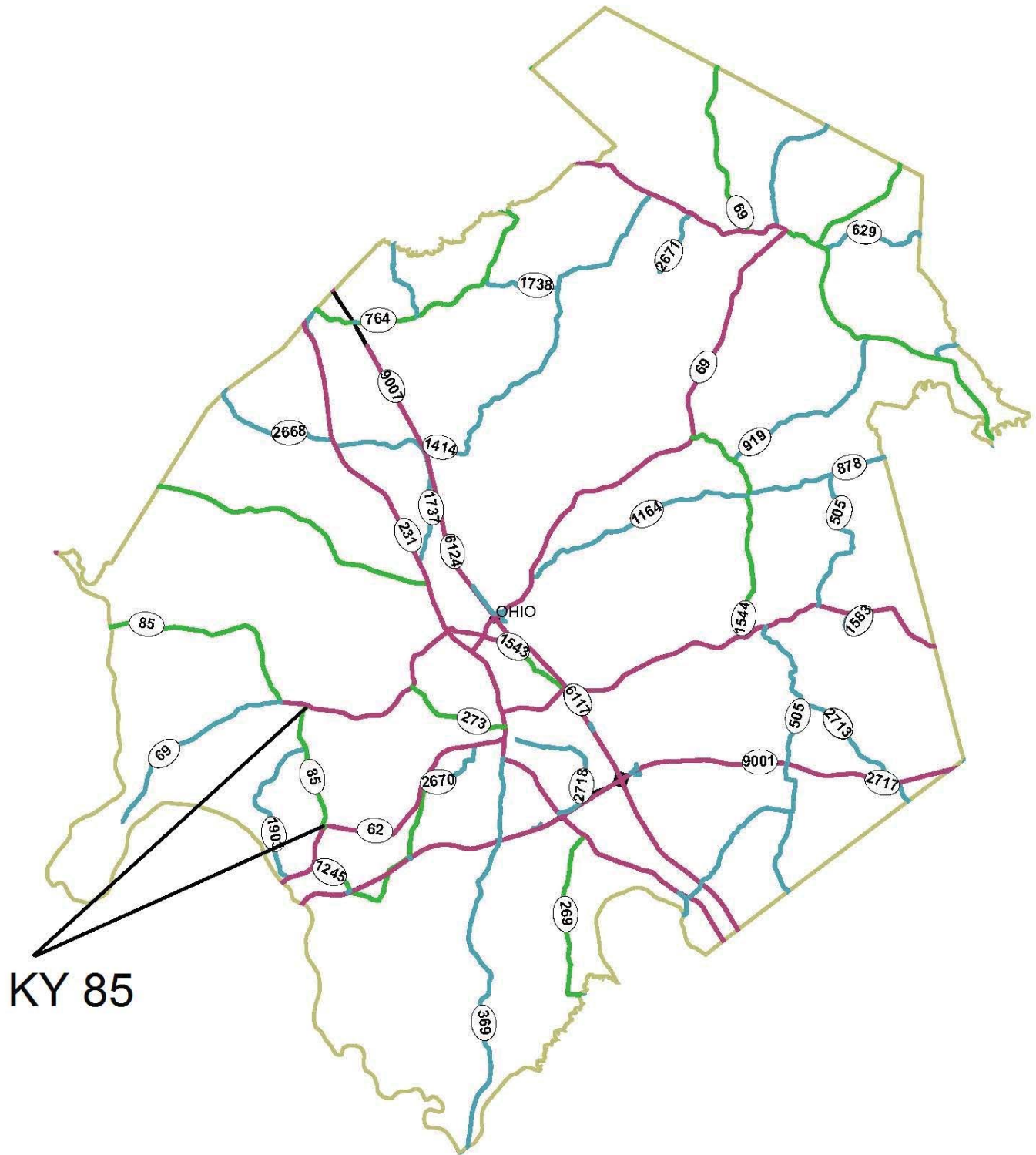

KY 85

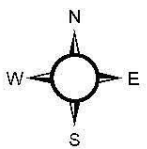

OHIO

KY 762

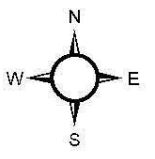
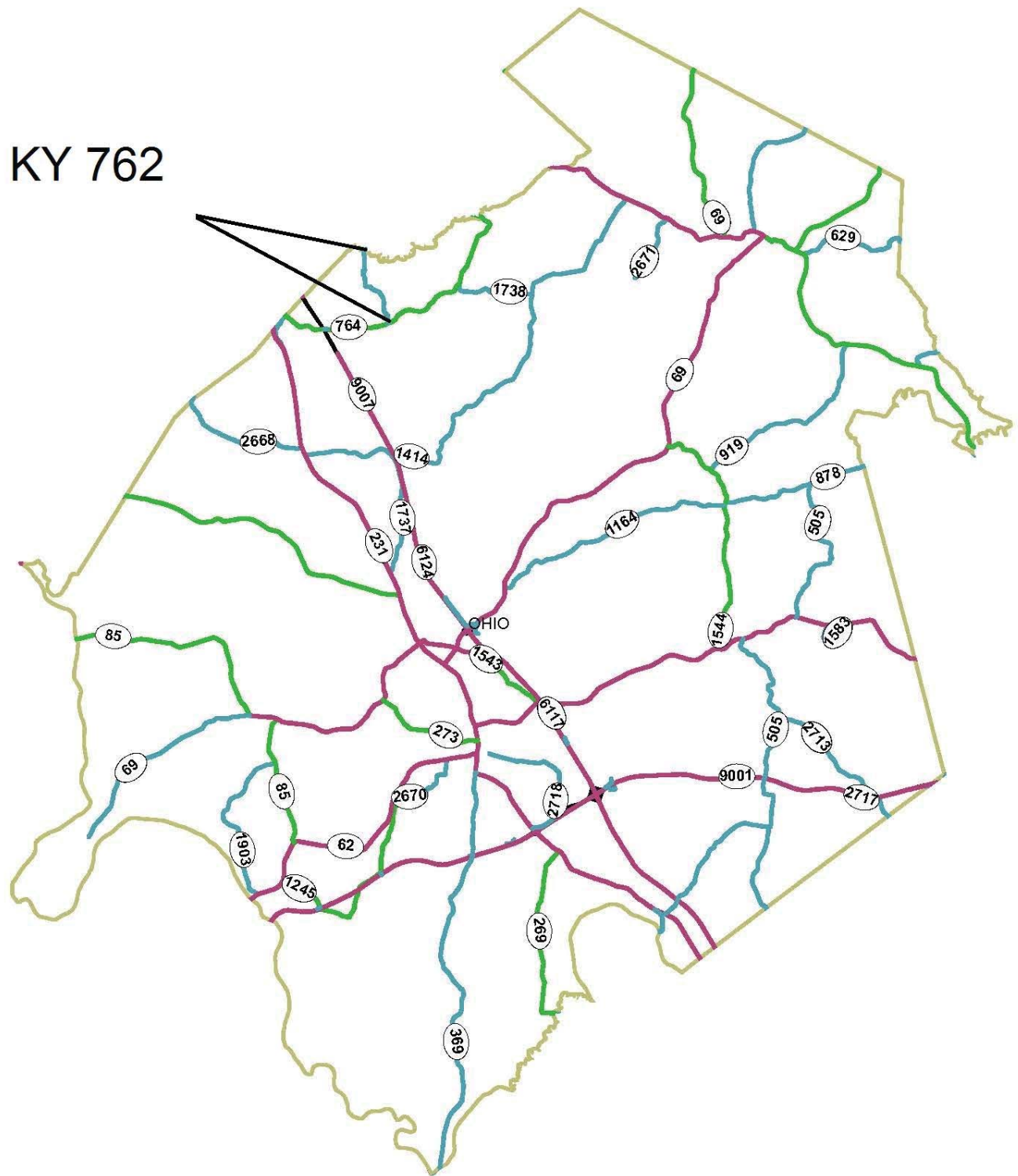

OHIO

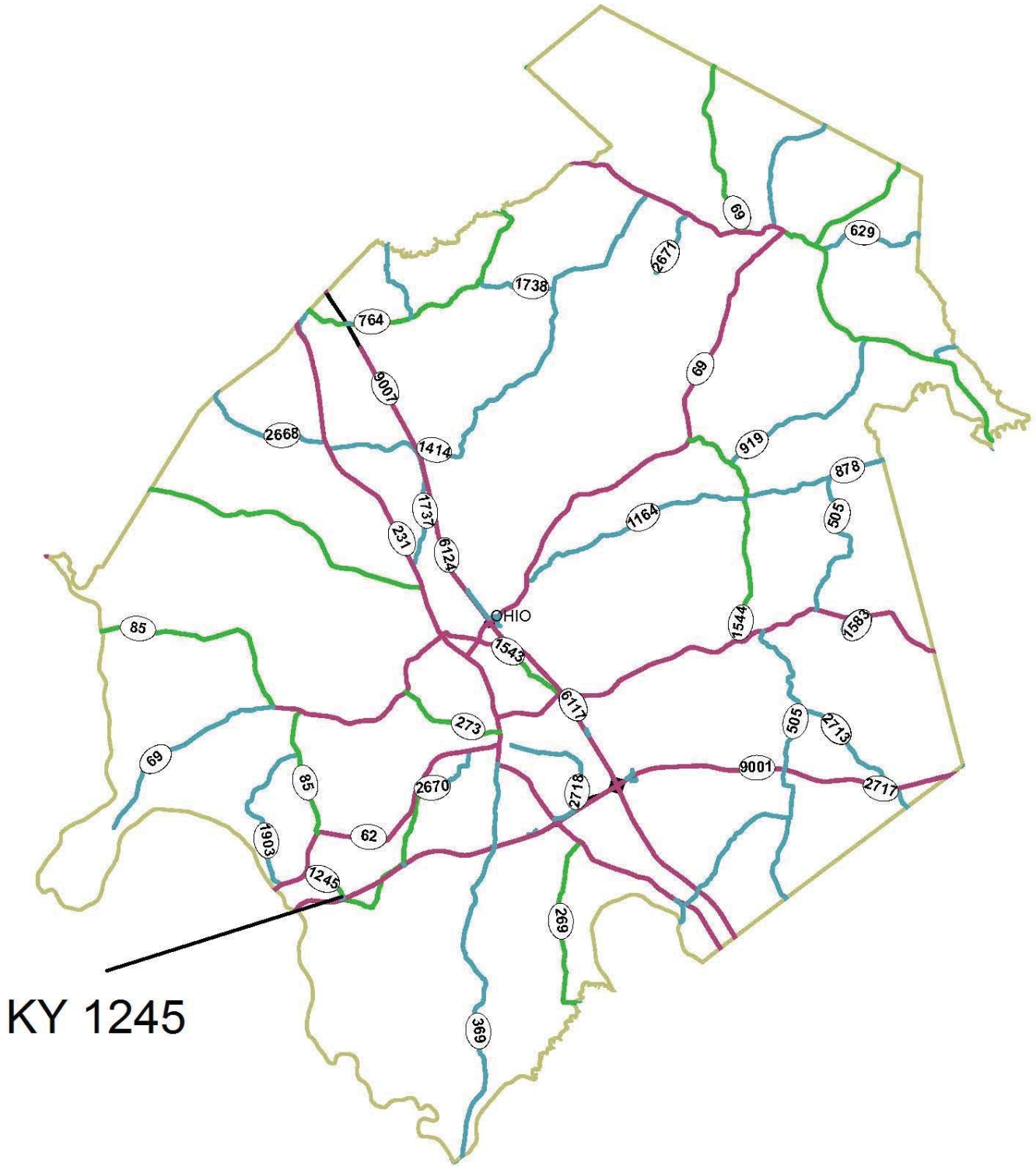

KY 1245

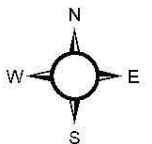

MATERIAL SUMMARY

CONTRACT ID: 183235**092GR18R028-CB06****0209200852018**

KY 85 (KY 85) FROM KY 69 EXTENDING SOUTH TO US 62 ASPHALT RESURFACING, A DISTANCE OF 4.09 MILES.

Project Line No	Bid Code	DESCRIPTION	Quantity	Unit
0005	02562	TEMPORARY SIGNS	330.00	SQFT
0010	02650	MAINTAIN & CONTROL TRAFFIC - KY 85	1.00	LS
0015	00301	CL2 ASPH SURF 0.38D PG64-22	3,485.00	TON
0020	00001	DGA BASE	555.00	TON
0025	24970EC	ASPHALT MATERIAL FOR TACK NON-TRACKING - (REVISED: 10-17-18)	35.00	TON
0030	00190	LEVELING & WEDGING PG64-22	438.00	TON
0035	02676	MOBILIZATION FOR MILL & TEXT - KY 85	1.00	LS
0040	02677	ASPHALT PAVE MILLING & TEXTURING	60.00	TON
0045	02697	EDGELINE RUMBLE STRIPS	43,200.00	LF
0050	06514	PAVE STRIPING-PERM PAINT-4 IN	34,253.00	LF
0055	06510	PAVE STRIPING-TEMP PAINT-4 IN	34,253.00	LF
0060	02569	DEMOBILIZATION	1.00	LS
0065	10030NS	ASPHALT ADJUSTMENT	15,337.00	DOLL
0070	10020NS	FUEL ADJUSTMENT	6,306.00	DOLL

CONTRACT ID: 183235**092GR18R028-CB06****0209207622018**

KY 762 (KY 762) FROM KY 764 EXTENDING NORTH TO DAVIESS COUNTY LINE ASPHALT RESURFACING, A DISTANCE OF 2.75 MILES.

Project Line No	Bid Code	DESCRIPTION	Quantity	Unit
0075	02562	TEMPORARY SIGNS	240.00	SQFT
0080	02650	MAINTAIN & CONTROL TRAFFIC - KY 762	1.00	LS
0085	00301	CL2 ASPH SURF 0.38D PG64-22	1,835.00	TON
0090	00001	DGA BASE	375.00	TON
0095	00190	LEVELING & WEDGING PG64-22	181.00	TON
0100	02676	MOBILIZATION FOR MILL & TEXT - KY 762	1.00	LS
0105	02677	ASPHALT PAVE MILLING & TEXTURING	30.00	TON
0110	06514	PAVE STRIPING-PERM PAINT-4 IN	28,000.00	LF
0115	06510	PAVE STRIPING-TEMP PAINT-4 IN	28,000.00	LF
0120	10030NS	ASPHALT ADJUSTMENT	7,882.00	DOLL
0125	10020NS	FUEL ADJUSTMENT	3,138.00	DOLL
0130	02569	DEMOBILIZATION	1.00	LS
0135	24970EC	ASPHALT MATERIAL FOR TACK NON-TRACKING - (REVISED: 10-17-18)	10.00	TON

MATERIAL SUMMARY

CONTRACT ID: 183235**092GR18R028-CB06****0209212452018**

KY 1245 (KY 1245) FROM 0.015 MILE NORTH OF KY 2719 EXTENDING NORTH TO 0.061 MILE NORTH OF KY 2719 BRIDGE DECK OVERLAY, A DISTANCE OF .08 MILES.

Project Line No	Bid Code	DESCRIPTION	Quantity	Unit
0140	02562	TEMPORARY SIGNS	250.00	SQFT
0145	02650	MAINTAIN & CONTROL TRAFFIC - KY 1245	1.00	LS
0150	00001	DGA BASE	25.00	TON
0155	02653	LANE CLOSURE	2.00	EACH
0160	02569	DEMOBILIZATION	1.00	LS
0165	03304	BRIDGE OVERLAY APPROACH PAVEMENT	550.00	SQYD
0170	08551	MACHINE PREP OF SLAB	525.00	SQYD
0175	03299	ARMORED EDGE FOR CONCRETE	50.00	LF
0180	06549	PAVE STRIPING-TEMP REM TAPE-B	500.00	LF
0185	06550	PAVE STRIPING-TEMP REM TAPE-W	500.00	LF
0190	04934	TEMP SIGNAL MULTI PHASE	1.00	EACH
0195	06514	PAVE STRIPING-PERM PAINT-4 IN	850.00	LF
0200	06551	PAVE STRIPING-TEMP REM TAPE-Y	1,000.00	LF
0205	03300	ELIMINATE TRANSVERSE JOINT	75.00	LF
0210	08534	CONCRETE OVERLAY-LATEX	19.00	CUYD
0215	08549	BLAST CLEANING	650.00	SQYD
0220	24094EC	PARTIAL DEPTH PATCHING	15.00	CUYD
0225	08526	CONC CLASS M FULL DEPTH PATCH	10.00	CUYD
0230	08150	STEEL REINFORCEMENT	670.00	LB
0235	08504	EPOXY SAND SLURRY	150.00	SQYD

**CB06 092 0085 007-012
TYPICAL SECTION
MP 7.201 TO MP 11.292**

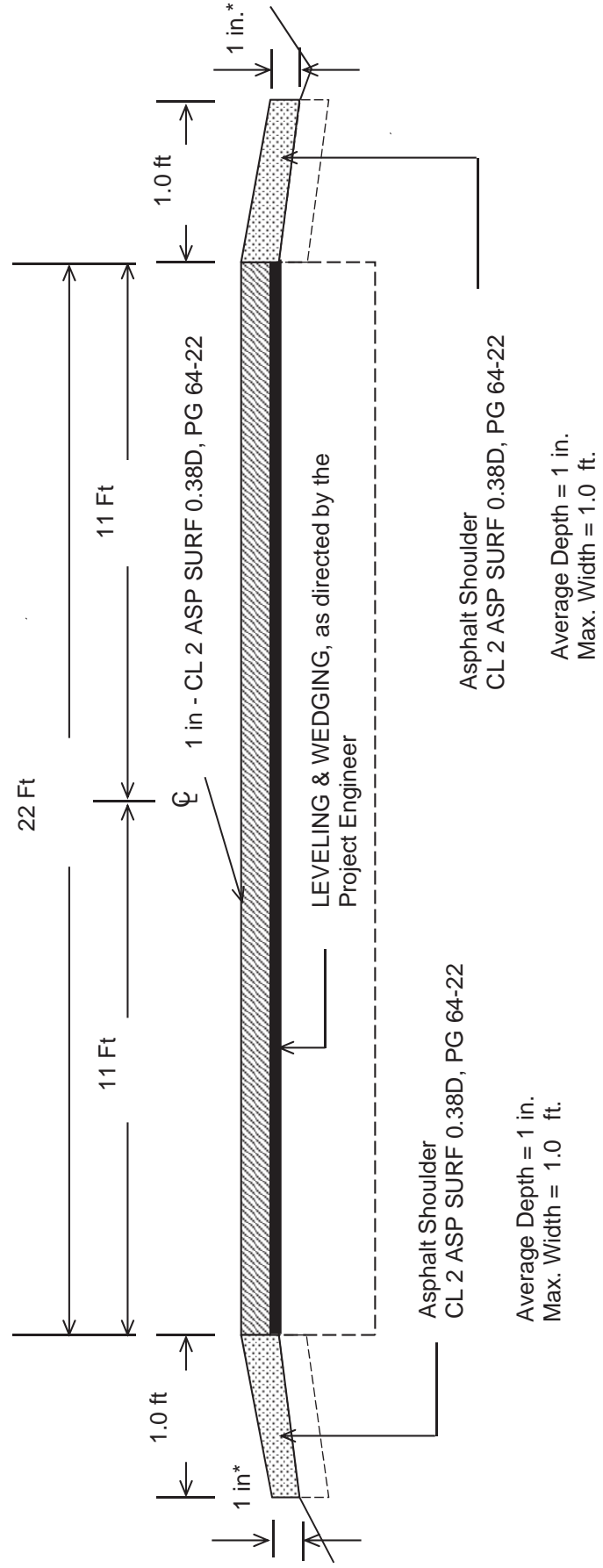

***Where Existing Site Conditions Permit**
 Add 1.0ft wide DGA varying between one and two inches in depth throughout project.
 Striping as directed by the Engineer

TYPICAL SECTION
OHIO COUNTY
CB06 092-0762-000-003

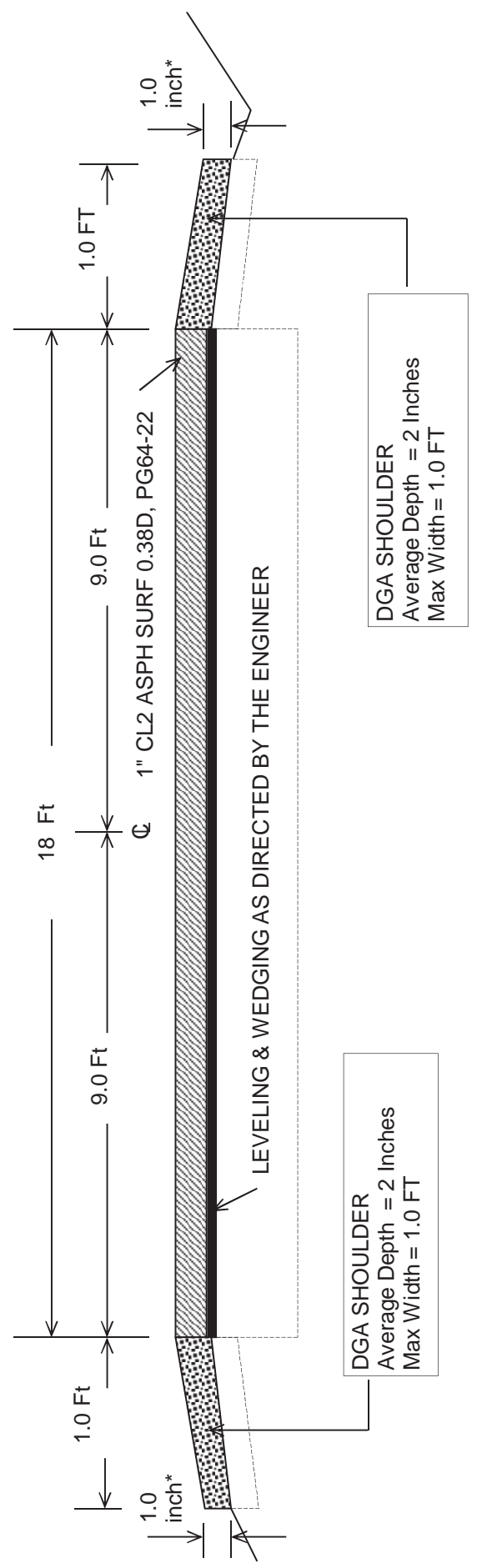

*** Where Existing Site Conditions Permit**
Striping as directed by the Engineer

**CONSTRUCTION DETAIL FOR BRIDGE WITHIN LIMITS OF
PAVING PROJECT
CB06 092 1245 001-002**

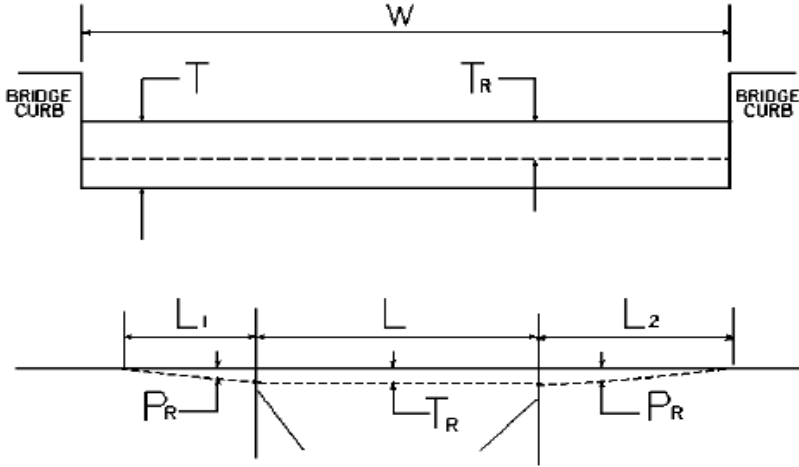

W = bridge width curb to curb T = thickness of existing bituminous overlay L = length of bridge
 L_1 & L_2 = length of approach pavement to be removed
 T_R = thickness to be removed and replaced on bridge P_R = thickness to be removed and replaced on pavement
Note: L_1 & L_2 lengths shall be determined by using a transition rate of 100 ft / inch of thickness

BRIDGE NO	MP	W (ft)	T (in)	L ₁ (ft)	L ₂ (ft)	T _R (in)	L (ft)	P _R (in)
B00108N	1.476	24.00	0.00	100.00	50.00	0.00	197.00	0.00

PART II
SPECIFICATIONS AND STANDARD DRAWINGS

SPECIFICATIONS REFERENCE

Any reference in the plans or proposal to previous editions of the *Standard Specifications for Road and Bridge Construction* and *Standard Drawings* are superseded by *Standard Specifications for Road and Bridge Construction, Edition of 2012* and *Standard Drawings, Edition of 2016*.

SUPPLEMENTAL SPECIFICATIONS

The contractor shall use the Supplemental Specifications that are effective at the time of letting.
The Supplemental Specifications can be found at the following link:

<http://transportation.ky.gov/Construction/Pages/Kentucky-Standard-Specifications.aspx>

2016 STANDARD DRAWINGS THAT APPLY

ROADWAY ~GENERAL~

MISCELLANEOUS STANDARDS

MISCELLANEOUS STANDARDS PART 1.....RGX-001-06

~PAVEMENT~

MEDIANS, CURBS, APPROACHES, ENTRANCES, ETC.

APPROACHES, ENTRANCES, AND MAIL BOX TURNOUT.....RPM-110-07

TRAFFIC ~TEMPORARY~

DEVICES

LANE CLOSURE TWO-LANE HIGHWAYTTC-100-04

PART III

EMPLOYMENT, WAGE AND RECORD REQUIREMENTS

**TRANSPORTATION CABINET
DEPARTMENT OF HIGHWAYS**

**LABOR AND WAGE REQUIREMENTS
APPLICABLE TO OTHER THAN FEDERAL-AID SYSTEM PROJECTS**

- I. Application
- II. Nondiscrimination of Employees (KRS 344)

I. APPLICATION

1. These contract provisions shall apply to all work performed on the contract by the contractor with his own organization and with the assistance of workmen under his immediate superintendence and to all work performed on the contract by piecework, station work or by subcontract. The contractor's organization shall be construed to include only workmen employed and paid directly by the contractor and equipment owned or rented by him, with or without operators.

2. The contractor shall insert in each of his subcontracts all of the stipulations contained in these Required Provisions and such other stipulations as may be required.

3. A breach of any of the stipulations contained in these Required Provisions may be grounds for termination of the contract.

3. If the contractor is in control of apprenticeship or other training or retraining, including on-the-job training programs, he shall not discriminate against an individual because of his race, color, religion, national origin, sex, disability or age forty (40) and over, in admission to, or employment in any program established to provide apprenticeship or other training.

4. The contractor will send to each labor union or representative of workers with which he has a collective bargaining agreement or other contract or understanding, a notice to be provided advising the said labor union or workers' representative of the contractor's commitments under this section, and shall post copies of the notice in conspicuous places available to employees and applicants for employment. The contractor will take such action with respect to any subcontract or purchase order as the administrating agency may direct as a means of enforcing such provisions, including sanctions for non-compliance.

Revised: January 25, 2017

II. NONDISCRIMINATION OF EMPLOYEES

**AN ACT OF THE KENTUCKY
GENERAL ASSEMBLY TO PREVENT
DISCRIMINATION IN EMPLOYMENT
KRS CHAPTER 344
EFFECTIVE JUNE 16, 1972**

The contract on this project, in accordance with KRS Chapter 344, provides that during the performance of this contract, the contractor agrees as follows:

1. The contractor shall not fail or refuse to hire, or shall not discharge any individual, or otherwise discriminate against an individual with respect to his compensation, terms, conditions, or privileges of employment, because of such individual's race, color, religion, national origin, sex, disability or age (forty and above); or limit, segregate, or classify his employees in any way which would deprive or tend to deprive an individual of employment opportunities or otherwise adversely affect his status as an employee, because of such individual's race, color, religion, national origin, sex, disability or age forty (40) and over. The contractor agrees to post in conspicuous places, available to employees and applicants for employment, notices to be provided setting forth the provisions of this nondiscrimination clause.

2. The contractor shall not print or publish or cause to be printed or published a notice or advertisement relating to employment by such an employer or membership in or any classification or referral for employment by the employment agency, indicating any preference, limitation, specification, or discrimination, based on race, color, religion, national origin, sex, or age forty (40) and over, or because the person is a qualified individual with a disability, except that such a notice or advertisement may indicate a preference, limitation, or specification based on religion, national origin, sex, or age forty (40) and over, or because the person is a qualified individual with a disability, when religion, national origin, sex, or age forty (40) and over, or because the person is a qualified individual with a disability, is a bona fide occupational qualification for employment.

EXECUTIVE BRANCH CODE OF ETHICS

In the 1992 regular legislative session, the General Assembly passed and Governor Brereton Jones signed Senate Bill 63 (codified as KRS 11A), the Executive Branch Code of Ethics, which states, in part:

KRS 11A.040 (7) provides:

No present or former public servant shall, within six (6) months following termination of his office or employment, accept employment, compensation, or other economic benefit from any person or business that contracts or does business with, or is regulated by, the state in matters in which he was directly involved during the last thirty-six (36) months of his tenure. This provision shall not prohibit an individual from returning to the same business, firm, occupation, or profession in which he was involved prior to taking office or beginning his term of employment, or for which he received, prior to his state employment, a professional degree or license, provided that, for a period of six (6) months, he personally refrains from working on any matter in which he was directly involved during the last thirty-six (36) months of his tenure in state government. This subsection shall not prohibit the performance of ministerial functions, including but not limited to filing tax returns, filing applications for permits or licenses, or filing incorporation papers, nor shall it prohibit the former officer or public servant from receiving public funds disbursed through entitlement programs.

KRS 11A.040 (9) states:

A former public servant shall not represent a person or business before a state agency in a matter in which the former public servant was directly involved during the last thirty-six (36) months of his tenure, for a period of one (1) year after the latter of:

- a) The date of leaving office or termination of employment; or
- b) The date the term of office expires to which the public servant was elected.

This law is intended to promote public confidence in the integrity of state government and to declare as public policy the idea that state employees should view their work as a public trust and not as a way to obtain private benefits.

If you have worked for the executive branch of state government within the past six months, you may be subject to the law's prohibitions. The law's applicability may be different if you hold elected office or are contemplating representation of another before a state agency.

Also, if you are affiliated with a firm which does business with the state and which employs former state executive-branch employees, you should be aware that the law may apply to them.

In case of doubt, the law permits you to request an advisory opinion from the Executive Branch Ethics Commission, 3 Fountain Place, Frankfort, Kentucky 40601; telephone (502) 564-7954.

Revised: January 27, 2017

Kentucky Equal Employment Opportunity Act of 1978

The requirements of the Kentucky Equal Employment Opportunity Act of 1978 (KRS 45.560-45.640) shall apply to this Contract. The apparent low Bidder will be required to submit EEO forms to the Division of Construction Procurement, which will then forward to the Finance and Administration Cabinet for review and approval. No award will become effective until all forms are submitted and EEO/CC has certified compliance. The required EEO forms are as follows:

- EEO-1: Employer Information Report
- Affidavit of Intent to Comply
- Employee Data Sheet
- Subcontractor Report

These forms are available on the Finance and Administration's web page under ***Vendor Information, Standard Attachments and General Terms*** at the following address:
<https://www.eProcurement.ky.gov>.

Bidders currently certified as being in compliance by the Finance and Administration Cabinet may submit a copy of their approval letter in lieu of the referenced EEO forms.

For questions or assistance please contact the Finance and Administration Cabinet by email at **finance.contractcompliance@ky.gov** or by phone at 502-564-2874.

EMPLOYEE RIGHTS UNDER THE FAIR LABOR STANDARDS ACT

THE UNITED STATES DEPARTMENT OF LABOR WAGE AND HOUR DIVISION

FEDERAL MINIMUM WAGE

\$7.25

 PER HOUR

BEGINNING JULY 24, 2009

OVERTIME PAY At least 1½ times your regular rate of pay for all hours worked over 40 in a workweek.

CHILD LABOR An employee must be at least **16** years old to work in most non-farm jobs and at least **18** to work in non-farm jobs declared hazardous by the Secretary of Labor.

Youths **14** and **15** years old may work outside school hours in various non-manufacturing, non-mining, non-hazardous jobs under the following conditions:

No more than

- **3** hours on a school day or **18** hours in a school week;
- **8** hours on a non-school day or **40** hours in a non-school week.

Also, work may not begin before **7 a.m.** or end after **7 p.m.**, except from June 1 through Labor Day, when evening hours are extended to **9 p.m.** Different rules apply in agricultural employment.

TIP CREDIT Employers of “tipped employees” must pay a cash wage of at least \$2.13 per hour if they claim a tip credit against their minimum wage obligation. If an employee’s tips combined with the employer’s cash wage of at least \$2.13 per hour do not equal the minimum hourly wage, the employer must make up the difference. Certain other conditions must also be met.

ENFORCEMENT The Department of Labor may recover back wages either administratively or through court action, for the employees that have been underpaid in violation of the law. Violations may result in civil or criminal action.

Employers may be assessed civil money penalties of up to \$1,100 for each willful or repeated violation of the minimum wage or overtime pay provisions of the law and up to \$11,000 for each employee who is the subject of a violation of the Act’s child labor provisions. In addition, a civil money penalty of up to \$50,000 may be assessed for each child labor violation that causes the death or serious injury of any minor employee, and such assessments may be doubled, up to \$100,000, when the violations are determined to be willful or repeated. The law also prohibits discriminating against or discharging workers who file a complaint or participate in any proceeding under the Act.

ADDITIONAL INFORMATION

- Certain occupations and establishments are exempt from the minimum wage and/or overtime pay provisions.
- Special provisions apply to workers in American Samoa and the Commonwealth of the Northern Mariana Islands.
- Some state laws provide greater employee protections; employers must comply with both.
- The law requires employers to display this poster where employees can readily see it.
- Employees under 20 years of age may be paid \$4.25 per hour during their first 90 consecutive calendar days of employment with an employer.
- Certain full-time students, student learners, apprentices, and workers with disabilities may be paid less than the minimum wage under special certificates issued by the Department of Labor.

For additional information:



1-866-4-USWAGE

(1-866-487-9243) TTY: 1-877-889-5627



WWW.WAGEHOUR.DOL.GOV

PART IV
INSURANCE

INSURANCE

The Contractor shall procure and maintain the following insurance in addition to the insurance required by law:

- 1) Commercial General Liability-Occurrence form – not less than \$2,000,000 General aggregate, \$2,000,000 Products & Completed Aggregate, \$1,000,000 Personal & Advertising, \$1,000,000 each occurrence.
- 2) Automobile Liability- \$1,000,000 per accident
- 3) Employers Liability:
 - a) \$100,000 Each Accident Bodily Injury
 - b) \$500,000 Policy limit Bodily Injury by Disease
 - c) \$100,000 Each Employee Bodily Injury by Disease
- 4) The insurance required above must be evidenced by a Certificate of Insurance and this Certificate of Insurance must contain one of the following statements:
 - a) "policy contains no deductible clauses."
 - b) "policy contains _____ (amount) deductible property damage clause but company will pay claim and collect the deductible from the insured."
- 5) **KENTUCKY WORKMEN'S COMPENSATION INSURANCE.** The contractor shall furnish evidence of coverage of all his employees or give evidence of self-insurance by submitting a copy of a certificate issued by the Workmen's Compensation Board.

The cost of insurance is incidental to all contract items. All subcontractors must meet the same minimum insurance requirements.

PART V
BID ITEMS

PROPOSAL BID ITEMS

REVISED ADDENDUM #1: 10-17-18

183235

Page 1 of 2

Report Date 10/17/18

Section: 0001 - PAVING

LINE	BID CODE	ALT	DESCRIPTION	QUANTITY	UNIT	UNIT PRIC	FP	AMOUNT
0010	00001		DGA BASE	955.00	TON		\$	
0020	00190		LEVELING & WEDGING PG64-22	619.00	TON		\$	
0030	00301		CL2 ASPH SURF 0.38D PG64-22	5,320.00	TON		\$	
0050	02562		TEMPORARY SIGNS	820.00	SQFT		\$	
0060	02650		MAINTAIN & CONTROL TRAFFIC KY 1245	1.00	LS		\$	
0070	02650		MAINTAIN & CONTROL TRAFFIC KY 762	1.00	LS		\$	
0080	02650		MAINTAIN & CONTROL TRAFFIC KY 85	1.00	LS		\$	
0090	02653		LANE CLOSURE	2.00	EACH		\$	
0100	02676		MOBILIZATION FOR MILL & TEXT KY 762	1.00	LS		\$	
0110	02676		MOBILIZATION FOR MILL & TEXT KY 85	1.00	LS		\$	
0120	02677		ASPHALT PAVE MILLING & TEXTURING	90.00	TON		\$	
0130	02697		EDGE LINE RUMBLE STRIPS	43,200.00	LF		\$	
0140	04934		TEMP SIGNAL MULTI PHASE	1.00	EACH		\$	
0150	06510		PAVE STRIPING-TEMP PAINT-4 IN	62,253.00	LF		\$	
0160	06514		PAVE STRIPING-PERM PAINT-4 IN	63,103.00	LF		\$	
0170	06549		PAVE STRIPING-TEMP REM TAPE-B	500.00	LF		\$	
0180	06550		PAVE STRIPING-TEMP REM TAPE-W	500.00	LF		\$	
0190	06551		PAVE STRIPING-TEMP REM TAPE-Y	1,000.00	LF		\$	
0200	10020NS		FUEL ADJUSTMENT	9,444.00	DOLL	\$1.00	\$	\$9,444.00
0210	10030NS		ASPHALT ADJUSTMENT	23,219.00	DOLL	\$1.00	\$	\$23,219.00
0220	24970EC		ASPHALT MATERIAL FOR TACK NON- TRACKING (REVISED: 10-17-18)	45.00	TON		\$	

Section: 0002 - BRIDGE

LINE	BID CODE	ALT	DESCRIPTION	QUANTITY	UNIT	UNIT PRIC	FP	AMOUNT
0230	03299		ARMORED EDGE FOR CONCRETE	50.00	LF		\$	
0240	03300		ELIMINATE TRANSVERSE JOINT	75.00	LF		\$	
0250	03304		BRIDGE OVERLAY APPROACH PAVEMENT	550.00	SQYD		\$	
0260	08150		STEEL REINFORCEMENT	670.00	LB		\$	
0270	08504		EPOXY SAND SLURRY	150.00	SQYD		\$	
0280	08526		CONC CLASS M FULL DEPTH PATCH	10.00	CUYD		\$	
0290	08534		CONCRETE OVERLAY-LATEX	19.00	CUYD		\$	
0300	08549		BLAST CLEANING	650.00	SQYD		\$	
0310	08551		MACHINE PREP OF SLAB	525.00	SQYD		\$	
0320	24094EC		PARTIAL DEPTH PATCHING	15.00	CUYD		\$	

Section: 0003 - DEMOBILIZATION

LINE	BID CODE	ALT	DESCRIPTION	QUANTITY	UNIT	UNIT PRIC	FP	AMOUNT
------	----------	-----	-------------	----------	------	-----------	----	--------

183235

PROPOSAL BID ITEMS

Page 2 of 2

Report Date 10/17/18

LINE	BID CODE	ALT	DESCRIPTION	QUANTITY	UNIT	UNIT PRIC	FP	AMOUNT
0330	02569		DEMOBILIZATION	1.00	LS		\$	